

Order no.: REF-30215309-2

Assembly carriage with central locking

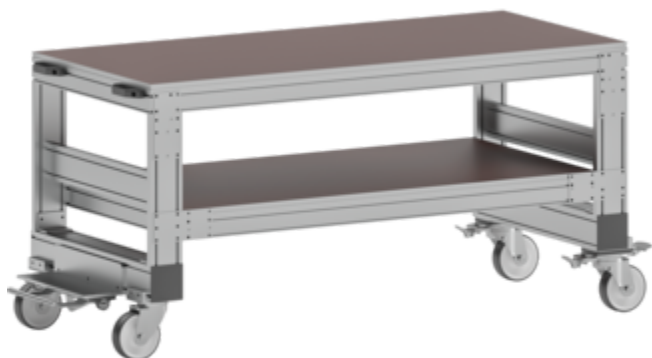

Specification

Business division MUNK Günzburger Steigtechnik	Sector Transport logistics	Type mobile	Height fixed
--	--------------------------------------	-----------------------	------------------------

Facts

- Platform width (PFB): 800 mm
- Platform length (PFL): 1,800 mm
- Top edge of platform 1: (PFH1) 900 mm
- Top edge of platform 2: (PFH2) 484 mm
- Platform covering: Wood screen printing
- Chassis: ZBS 2-2
- 2 swivel castors (Ø 160 mm) operated by foot control lever
- 2 swivel castors (Ø 160 mm) with directional lock
- Foot control lever in the centre
- Total load: 500 kg

Description

Client's Request and Task

In the demanding environment of rolling door assembly for truck bodies, a specialized assembly trolley was required that not only enables ergonomic and safe working for employees but is also stable, reliable, and standard-compliant. A key feature should be the central locking system to optimize the handling and mobility of the trolley.

Customer Requirements

- Assembly trolley with central locking for rolling door assembly for truck bodies
- Ergonomic and safe working for employees
- Stable, reliable, and standard-compliant construction

Our Solution

Construction and Functionality

The assembly trolley, designed for the specific needs of rolling door assembly for truck bodies, features two storage surfaces and a chassis with a braking system. The lower platform is adjustable by 90 mm, offering flexible application possibilities. Two handles facilitate the transportation of the trolley.

Technical Specifications

The platform of the assembly trolley has a width of 800 mm and a length of 1800 mm. The height of the upper platform is 900 mm, and that of the lower is approximately 480 mm. The decking is made of robust wood screen-print.

Chassis and Maneuverability

The trolley is equipped with two steering casters controlled by a central foot-operated lever, as well as two steering casters with direction locks. With a wheel diameter of 160 mm, it offers high maneuverability and stability.

Load Capacities

The total load capacity of the assembly trolley is 500 kg, highlighting its robustness and versatility.

Conclusion

The assembly carriage with central locking is an ideal solution for the assembly of rolling doors for truck bodies. It combines flexibility and ergonomics with safety and reliability, thus meeting all the requirements of the demanding assembly environment.

Information on sustainability criteria

- Corporate certification: ISO 9001
- Corporate certification: ISO 14001
- Corporate certification: EN 1090
- Corporate certification: EcoVadis

- RoHS
- REACH
- The MUNK Group complies with a Code of Conduct
- The Supply Chain Act does not apply due to our size
- The materials used are listed in the technical specification
- Resource-saving production: own photovoltaic systems
- Energy-efficient consumption during production: LED lighting
- Repairability, durability and quality: 15-year warranty on series products made in Germany
- Recyclability: Our products are mostly made of aluminium, steel or wood and can be fed directly into the recycling process.
- Socially acceptable working conditions in production: fair wages, gender equality
- Economical and recyclable packaging: no use of polystyrene, predominantly use of wood and cardboard, small amounts of plastic
- No health hazards for the users

More product pictures

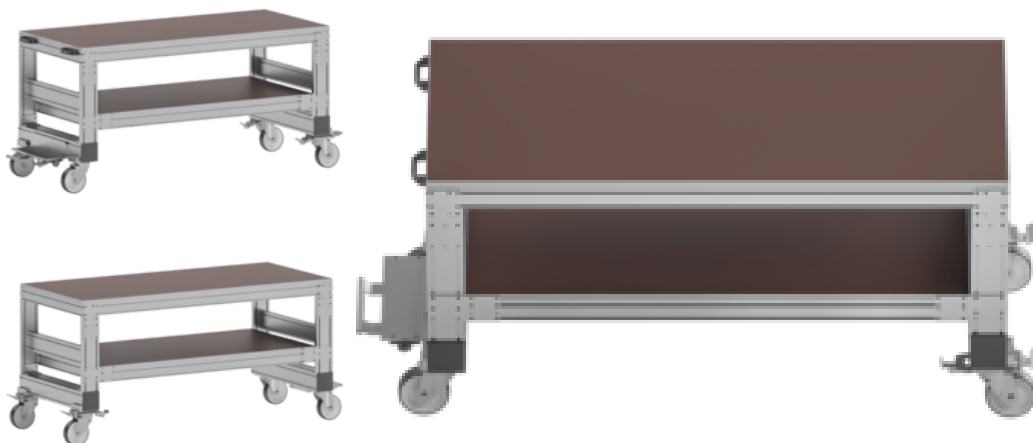

Added value

Trust in us as your competent partner in the field of individual access equipment solutions. We are industry leaders from analysis to conception and design to first-class after-sales service.

★ Analysis

We set standards in the evaluation of access equipment requirements. Our experts take sufficient time to understand your specific needs. After a thorough analysis, we will present you with a tailor-made design that is perfectly tailored to your individual circumstances. Rely on us to identify your challenges and solve them in an innovative way.

★ Concept

We are leaders in the planning of special designs. With creativity, technical know-how and a deep understanding of access equipment, we develop pioneering concepts. Our experienced team designs outstanding solutions that meet the highest safety standards and maximise your efficiency and ergonomics. Let yourself be impressed by our competence and innovative strength.

★ Design

We set the bar high in design. Our engineers and production planners have unique specialist knowledge and many years of experience in the field of access equipment. With the latest technologies and high-quality materials we realise your concept down to the smallest detail. Precision and quality are the first priority – for your special designs that meet the highest demands.

★ Production

In our modern production halls at our headquarters in Günzburg, we can implement your planning and wishes professionally and efficiently. Our specialists in access equipment, electronics and mechanics always have only one thing in mind: Quality that delivers what it promises. That's why every design, whether

From decades of experience, we know that individual requirements require special solutions. That's why we are here to help you realize your custom construction.

Get inspired by our reference products and make your unique idea a success. We look forward to supporting your project with our expertise and dedication. Contact our competent team for more information and assistance.

With MUNK Group by your side, your custom construction becomes a reality: Safety. Made in Germany.

What we offer

- On-site consultation and project planning
- Custom development according to your requirements
- Precision manufacturing
- Functional and cost-effective access solutions
- Maximum workplace safety
- Fast delivery
- Compliance with all relevant German, English, and international standards and regulations, such as BetrSichV, DGUV regulations, Machinery Directive 2006/42/EC

[OPEN CONTACT FORM](#)



large or small, is manufactured with the highest quality and precision and thoroughly tested before shipment.

★ **After sales**

Our commitment does not end with the completion of the special design. We are unbeatable in after-sales service. With assembly, maintenance, testing and repairs, we ensure that your special design always remains in perfect condition. Our reliable team provides you with superior customer service and ensures that your satisfaction is first and foremost.



Corporate certifications

on sustainability criteria



Management System
ISO 9001:2015
ISO 14001:2015
www.tuv.com
ID 9108612548



Nachhaltigkeit
EcoVadis
sustainable supply management
CSR-Rating in Silber 2022

